

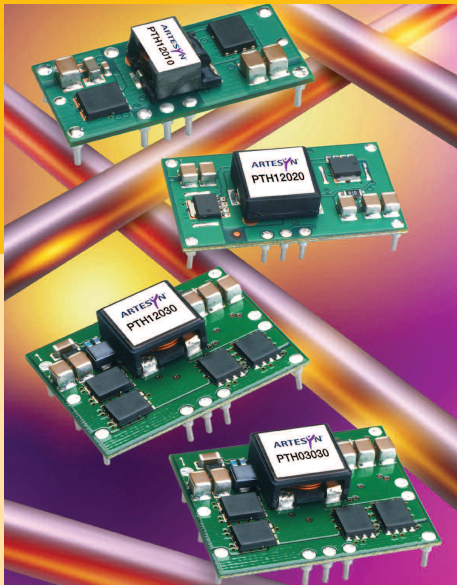

PTH03060 3.3Vin Single

Application Note 154

1. Introduction	2	3. Mechanical Information Cont'd	
2. System Interface Information		V _{out} Track	5
Input Capacitor	3	Margin Down	5
Output Capacitance (Optional)	3	Margin Up	5
Tantalum Capacitors	3	4. Packaging Information	
Ceramic Capacitors	3	Packaging	6
Capacitor Table	3	Labeling and Part Numbering Sequence	6
Designing for Very Fast Load Transients	3	5. Safety Information	
Recommended Input/Output Capacitors	4	Safety Standards and Approvals	6
3. Mechanical Information		Fuse Information	6
Mechanical Outline Drawings	5	Safety Considerations	6
Pin-out Table	5	6. Operating Information	
Pin Description	5	Overtemperature Protection (OTP)	7
Ground	5	Overcurrent Protection	7
V _{in}	5	Soft-Start Power-Up	7
Inhibit	5	7. Feature Set	
V _o Adjust	5	Adjusting the Output Voltage	8
V _o Sense	5	Output ON/OFF Inhibit	8
		Pre-bias Start-up Capability	9
		Margin Up/Down Controls	10
		Up/Down Adjust Resistance Calculation	10
		Remote Sense	10
		8. Thermal Information	
		Thermal Reference Points	11
		Safe Operating Curve	11
		Thermal Test Set-up	11
		9. Use in a Manufacturing Environment	
		Recommended Land Pattern	11
		10. Auto-Track™	
		Auto-Track™ Function	12
		How Auto-Track™ Works	12
		Typical Application	12
		Notes on the Use of Auto-Track™	12



POLA
Point-of-Load Alliance



1. Introduction

The PTH family of non-isolated, wide-output adjust power modules from Artesyn Technologies are optimized for applications that require a flexible, high performance module that is small in size. These products are part of the “Point-of-Load Alliance” (POLA), which ensures compatible footprint, interoperability and true second sourcing for customer design flexibility. The POLA is a collaboration between Artesyn Technologies, Astec Power and Texas Instruments to offer customers advanced non-isolated modules that provide the same functionality and form factor. Product series covered by the alliance includes the PTHxx050W (6 A), PTHxx060W (10 A), PTHxx010W (15/12 A), PTHxx020W (22/18 A), and the PTHxx030W (30/26 A).

From the basic, “Just Plug it In” functionality of the 6 A modules, to the 30 A rated feature-rich PTHxx030W, series these products were designed to be very flexible, yet simple to use. The features vary with each product series. Table 1 provides a quick reference to the available features by series and input bus voltage.

For simple point-of-use applications, the PTHxx050W series provides operating features such as an on/off inhibit, output voltage trim, pre-bias start-up (3.3/5 V input only), and overcurrent protection. The PTHxx060W (10 A), and PTHxx010W (15/12 A) series add an output voltage sense, and margin up/down controls. The higher output current, PTHxx020W and PTHxx030W series also incorporates overtemperature and shutdown protection. All of the products referenced in Table 1 include Auto-Track™. This is a feature unique to the PTH family, and was specifically designed to simplify the task of sequencing the supply voltage in a power system. These and other features are described in the following sections.

SERIES	INPUT BUS	I _{OUT}	ADJUST TRIM	ON/OFF INHIBIT	OVER-CURRENT	PRE-BIAS STARTUP	AUTO-TRACK™*	MARGIN UP/DOWN	OUTPUT SENSE	THERMAL SHUTDOWN
PTHxx050	3.3 V	6 A	●	●	●	●	●			
	5 V	6 A	●	●	●	●	●			
	12 V	6 A	●	●	●		●			
PTHxx060	3.3 V/5 V	10 A	●	●	●	●	●	●	●	
	12 V	10 A	●	●	●		●	●	●	
PTHxx010	3.3 V/5 V	15 A	●	●	●	●	●	●	●	
	12 V	12 A	●	●	●		●	●	●	
PTHxx020	3.3 V/5 V	22 A	●	●	●	●	●	●	●	●
	12 V	18 A	●	●	●		●	●	●	●
PTHxx030	3.3 V/5 V	30 A	●	●	●	●	●	●	●	●
	12 V	26 A	●	●	●	●	●	●	●	●

Table 1 - Operating Features by Series and Input Bus Voltage

RoHS Compliance Ordering Information	
	PTH03060WAST To order Pb-free (RoHS compatible) surface-mount parts replace the mounting option ‘S’ with ‘Z’, e.g. PTH03060WAZT. To order Pb-free (RoHS compatible) through-hole parts replace the mounting option ‘H’ with ‘D’, e.g. PTH03060WADT.

*Auto-track™ is a trade mark of Texas Instruments



2. System Interface Information

2.1 Input Capacitor

The recommended input capacitor(s) is determined by the 330 μF minimum capacitance and 500 mA rms minimum ripple current rating.

Ripple current, less than 150 m Ω equivalent series resistance (ESR), and temperature are the major considerations when selecting input capacitors. Unlike polymer tantalum, regular tantalum capacitors have a recommended minimum voltage rating of 2 x (maximum dc voltage + ac ripple). This is standard practice to ensure reliability.

For improved ripple reduction on the input bus, ceramic capacitors⁽¹⁾ may be used to complement electrolytic types to achieve the minimum required capacitance.

2.2 Output Capacitance (Optional)

For applications with load transients (sudden changes in load current), regulator response will benefit from an external output capacitance. The recommended output capacitance of 330 μF will allow the module to meet its transient response specification (see product datasheet). For most applications, a high quality computer-grade aluminum electrolytic capacitor is adequate. These capacitors provide decoupling over the frequency range, 2 kHz to 150 kHz, and are suitable for ambient temperatures above 0 $^{\circ}\text{C}$. For operation below 0 $^{\circ}\text{C}$ tantalum, ceramic or Os-Con type capacitors are recommended. When using one or more non-ceramic capacitors, the calculated equivalent ESR should be no lower than 4 m Ω (7 m Ω using the manufacturer's maximum ESR for a single capacitor). A list of preferred low-ESR type capacitors are identified in Table 2.

2.2.1 Tantalum Capacitors

Tantalum type capacitors can be used at both the input and output, and are recommended for applications where the ambient operating temperature can be less than 0 $^{\circ}\text{C}$. The AVX TPS, Sprague 593D/594/595 and Kemet T495/T510 capacitor series are suggested over many other tantalum types due to their higher rated surge, power dissipation, and ripple current capability. As a caution many general purpose tantalum capacitors have considerably higher ESR, reduced power dissipation and lower ripple current capability. These capacitors are also less reliable as they have lower power dissipation and surge current ratings. Tantalum capacitors that do not have a stated ESR or surge current rating are not recommended for power applications. When specifying Os-Con and polymer tantalum capacitors for the output, the minimum ESR limit will be encountered well before the maximum capacitance value is reached.

2.2.2 Ceramic Capacitors

Above 150 kHz the performance of aluminum electrolytic capacitors is less effective. Multilayer ceramic capacitors have very low ESR and a resonant frequency higher than the bandwidth of the regulator. They can be used to reduce the reflected ripple current at the input as well as improve the transient response of the output. When used on the output their combined ESR is not critical as long as the total value of ceramic capacitance does not exceed 300 μF . Also, to prevent the formation of local resonances, do not place more than five identical ceramic capacitors in parallel with values of 10 μF or greater.

2.2.3 Capacitor Table

Table 2 identifies the characteristics of capacitors from a number of vendors with acceptable ESR and ripple current (rms) ratings. The recommended number of capacitors required at both the input and output buses is identified for each capacitor type.

This is not an extensive capacitor list. Capacitors from other vendors are available with comparable specifications. Those listed are for guidance. The RMS ripple current rating and ESR (at 100 kHz) are critical parameters necessary to insure both optimum regulator performance and long capacitor life.

2.2.4 Designing for Very Fast Load Transients

The transient response of the dc-dc converter has been characterized using a load transient with a di/dt of 1 A/ μs . The typical voltage deviation for this load transient is given in the datasheet specification table using the optional value of output capacitance. As the di/dt of a transient is increased, the response of a converter's regulation circuit ultimately depends on its output capacitor decoupling network. This is an inherent limitation with any dc-dc converter once the speed of the transient exceeds its bandwidth capability. If the target application specifies a higher di/dt or lower voltage deviation, the requirement can only be met with additional output capacitor decoupling. In these cases special attention must be paid to the type, value and ESR of the capacitors selected.

If the transient performance requirements exceed that specified in the datasheet, or the total amount of load capacitance is above 3,000 μF , the selection of output capacitors becomes more important.

CAPACITOR VENDOR/ SERIES	CAPACITOR CHARACTERISTICS					QUANTITY		VENDOR PART NUMBER
	WORKING VOLTAGE	VALUE (μ F)	MAX. ESR AT 100 kHz	MAX RIPPLE CURRENT AT 85 °C (Irms)	PHYSICAL SIZE (MM) (L X W)	INPUT BUS	OPTIONAL OUTPUT BUS	
Panasonic, Aluminum FC (Radial)	10 V	330	0.117 Ω	555 mA	8.0 x 10.0	1	1	EEUFC1A331
FC (SMD)	25 V	470	0.080 Ω	850 mA	10.0 x 10.2	1	1	EEVFK1E471P
FC (SMD)	16 V	330	0.150 Ω	670 mA	10.0 x 10.2	1	1	EEVFC1C331P
United Chemi-Con PXA (SMD)	10 V	330	0.024 Ω	3770 mA	10.0 x 7.7	1	≤ 4	PXA10VC331MJ80TP
PS (Radial)	6.3 V	390	0.012 Ω	4770 mA	8.0 x 11.5	1	≤ 2	6PS390MH11
FX (Radial)	10 V	390	0.018 Ω	3710 mA	8.0 x 10.5	1	≤ 3	10FX390M
LXZ (Radial)	16 V	330	0.120 Ω	555 mA	8.0 x 12.5	1	1	LXZ16VB331M8X12LL
Nichicon WG (SMD)	25 V	330	0.150 Ω	670 mA	10.0 x 10.0	1	1	UWG1E331MNR1GS
HD (Radial)	16 V	330	0.072 Ω	760 mA	8.0 x 11.5	1	1	UHD1A331MPR
PM (Radial)	16 V	330	0.120 Ω	625 mA	10.0 x 12.5	1	1	UPM1C331MPH6
Panasonic, Aluminum WA (SMD)	10 V	330	0.022 Ω	4500 mA	10.0 x 10.2	1	≤ 4	EEFWA1A331P
S/SE (SMD)	6.3 V	180	0.005 Ω	4000 mA	7.3 x 4.3	2	≤ 1	EEFSE0J181R
SANYO SP, Os-Con (Radial)	10 V	470	0.015 Ω	4500 mA	10.0 x 10.5	1	≤ 2	10SP470M
SVP (SMT)	10 V	330	0.017 Ω	3950 mA	8.0 x 12.0	1	≤ 3	10SVP330M
TPE, Poscap (SMD)	6.3 V	330	0.025 Ω	2400 mA	7.3 x 4.3	1	≤ 4	6TPE330ML
AVX Tantalum TPS (SMD)	10 V	330	0.045 Ω	1723 mA	7.3 x 5.7	1	≤ 5	TPSE337M010R0045
TPS (SMD)	10 V	330	0.060 Ω	1826 mA	7.3 x 5.7	1	≤ 5	TPSV337M010R0060
Kemet Polymer Tantalum T520 (SMD)	10 V	330	0.040 Ω	1800 mA	7.3 x 4.3	1	1	T520X337M010AS
T530 (SMD)	10 V	330	0.015 Ω	>3800 mA	7.3 x 4.3	1	1	T530X337M010AS
Vishay-Sprague 595D (SMD)	10 V	330	0.100 Ω	1040 mA	7.2 x 6.0	1	≤ 5	595D337X0010D2T
594D (SMD)	10 V	330	0.045 Ω	2360 mA	7.2 x 6.0	1	≤ 5	594D337X0016R2T
94SA (Radial)	6.3 V	330	0.025 Ω	3500 mA	10.0 x 10.5	1	≤ 4	94SA337X06R3FBP
Kemet, Ceramic X5R (SMD)	16 V	10	0.002 Ω		1210 case	1	≤ 5	C1210C106M4PAC
	6.3 V	47			3225 mm	1	≤ 5	C1210C476K9PAC
Murata, Ceramic X5R (SMD)	6.3 V	100	0.002 Ω		1210 case	1	≤ 3	GRM32ER60J107M
	6.3 V	47			3225 mm	1	≤ 5	GRM32ER60J476M
	16 V	22				1	≤ 5	GRM32ER61C226K
	16 V	10				1	≤ 5	GRM32DR61C106K
TDK, Ceramic X5R (SMD)	6.3 V	100	0.002 Ω		1210 case	1	≤ 3	C3225X5R0J107MT
	6.3 V	47			3225 mm	1	≤ 5	C3225X5R0J476MT
	16 V	22				1	≤ 5	C3225X5R1C226MT
	16 V	10				1	≤ 5	C3225X5R1C106MT

(1) A ceramic capacitor may be used to compliment electrolytic types at the input to further reduce high-frequency ripple current

Table 2 - Recommended Input/Output Capacitors

3. Mechanical Information

3.1 Mechanical Outline Drawings

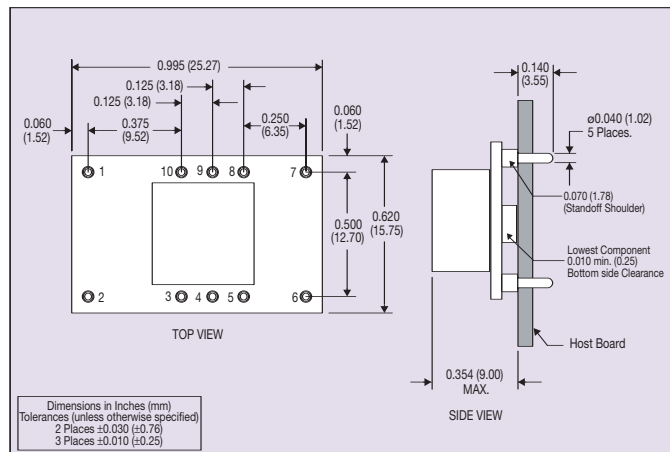

Figure 1 - Plated Through-Hole Mechanical Drawing

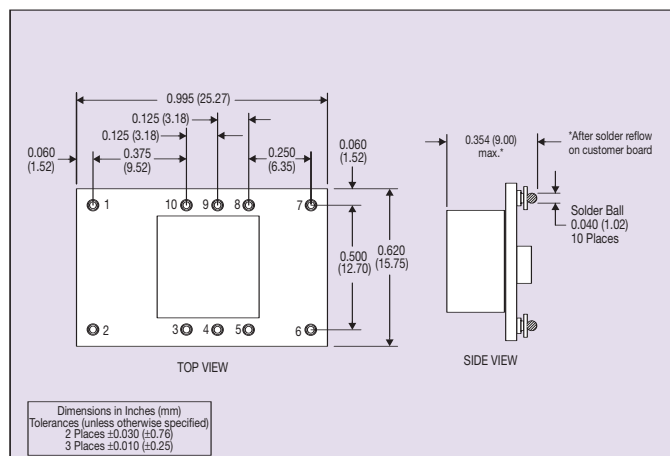

Figure 2 - Surface Mount Mechanical Drawing

3.2 Pin-out Table

PIN CONNECTIONS	
PIN NUMBER	FUNCTION
1	Ground
2	V _{in}
3	Inhibit
4	V _o Adjust
5	V _o Sense
6	V _{out}
7	Ground
8	Track
9	Margin Down
10	Margin Up

Table 3 - Pin Connections

3.3 Pin Description

3.3.1 Ground

This is the common ground connection for the V_{in} and V_{out} power connections. It is also the 0 Vdc reference for the control inputs.

3.3.2 Vin

The positive input voltage power node to the module, which is referenced to common GND.

3.3.3 Inhibit

The Inhibit pin is an open-collector/drain negative logic input that is referenced to GND. Applying a low level ground signal to this input disables the module's output and turns off the output voltage. When the Inhibit control is active, the input current drawn by the regulator is significantly reduced. If the Inhibit pin is left open-circuit, the module will produce an output whenever a valid input source is applied.

3.3.4 Vo Adjust

A 0.1 W 1% resistor must be directly connected between this pin and pin 7 (GND) to set the output voltage to a value higher than 0.8 V. The temperature stability of the resistor should be 100 ppm/°C (or better). The set point range for the output voltage is from 0.8 Vdc to 2.5 Vdc. The resistor value required for a given output voltage may be calculated from the following formula. If left open circuit, the output voltage will default to its lowest value. For further information on output voltage adjustment consult the related application note.

$$R_{set} = 10K \times \frac{0.8V}{V_{out} - 0.8V} - 2.49 \text{ k}\Omega$$

The specification table in Section 7.1, gives the preferred resistor values for a number of standard output voltages.

3.3.5 Vo Sense

The sense input allows the regulation circuit to compensate for voltage drop between the module and the load. For optimal voltage accuracy V_o Sense should be connected to V_{out}. It can also be left disconnected.

3.3.6 Vout

The regulated positive power output with respect to the GND node.

3.3.7 Track

This is an analog control input that enables the output voltage to follow an external voltage. This pin becomes active typically 20 ms after the input voltage has been applied, and allows direct control of the output voltage from 0 V up to the nominal set-point voltage. Within this range the output will follow the voltage at the Track pin on a volt-for-volt basis. When the control voltage is raised above this range, the module regulates at its set-point voltage. The feature allows the output voltage to rise simultaneously with other modules powered from the same input bus. If unused, this input should be connected to V_{in}. **Note:** Due to the under-voltage lockout feature, the output of the module cannot follow its own input voltage during power up. For more information, see Section 10.

3.3.8 Margin Down

When this input is asserted to GND, the output voltage is decreased by 5% from the nominal. The input requires an open-collector (open-drain) interface. It is not TTL compatible. A lower percent change can be accommodated with a series resistor, see Section 7.4.

3.3.9 Margin Up

When this input is asserted to GND, the output voltage is increased by 5%. The input requires an open-collector (open-drain) interface. It is not TTL compatible. The percent change can be reduced with a series resistor, see Section 7.4

4. Packaging Information

4.1 Packaging

The PTH03060 are available in trays of 24 units and tape and reel format in quantities of 250 units per reel. Tray and tape dimensions including pick point are shown in Figures 3 and 4.

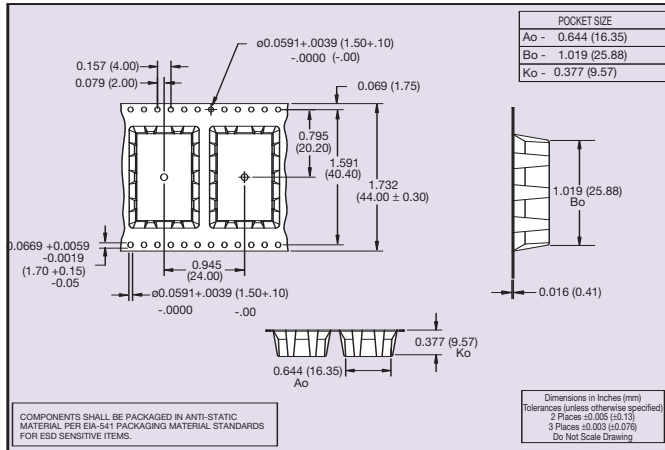

Figure 3 - Tape Dimensions

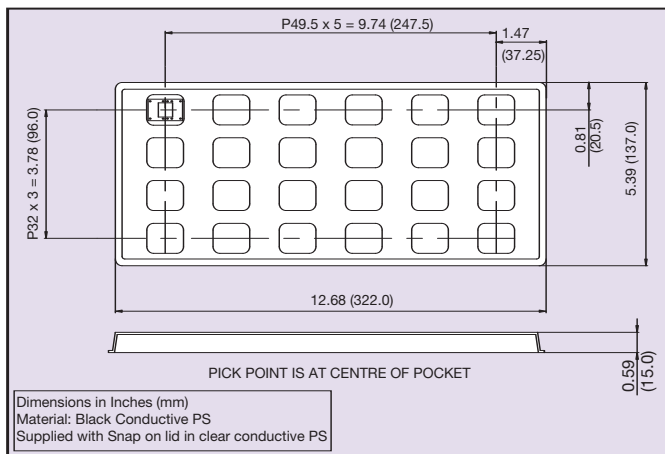

Figure 4 - Tray

4.2 Labeling and Part Numbering Sequence

All units in the series will be clearly marked to allow ease of identification for the end user. Figure 5 gives details of all the models.

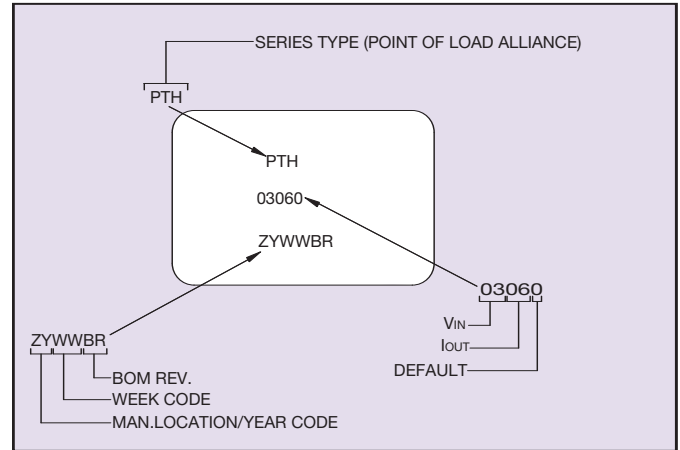

Figure 5 - PTH03060 Part Numbering

5. Safety Information

5.1 Safety Standards and Approvals

All models will have full international safety approval including EN60950 and UL/cUL1950. Models have been submitted to independent safety agencies for approval.

5.2 Fuse Information

Any suitable value fuse (based on the input ratings) maybe used in the unearthed input line. However this is not required for compliance with safety.

5.3 Safety Considerations

The converter must be installed as per guidelines outlined by the various safety agency approvals, if safety agency approval is required for the overall system.

6. Operating Information

6.1 Overtemperature Protection (OTP)

Only the PTHxx020 and PTHxx030 series of products have overtemperature protection. These products have an on-board temperature sensor that protects the module's internal circuitry against excessively high temperatures. A rise in the internal temperature may be the result of a drop in airflow, or a high ambient temperature. If the internal temperature exceeds the OTP threshold (see datasheet specifications), the module's Inhibit control is automatically pulled low. This disables the regulator allowing the output voltage to drop to zero. (The external output capacitors will be discharged by the load circuit). The recovery is automatic, and begins with a soft-start power up. It occurs when the sensed temperature decreases by about 10 °C below the trip point.

Note

The overtemperature protection is a last resort mechanism to prevent thermal stress to the regulator. Operation at or close to the thermal shutdown temperature is not recommended and will reduce the long-term reliability of the module. Always operate the regulator within the specified Safe Operating Area (SOA) limits for the worst-case conditions of ambient temperature and airflow.

6.2 Overcurrent Protection

For protection against load faults, all modules incorporate output overcurrent protection. Applying a load that exceeds the regulator's overcurrent threshold will cause the regulated output to shut down. Following shutdown a module will periodically attempt to recover by initiating a soft-start power-up. This is described as a "hiccup" mode of operation, whereby the module continues in the cycle of successive shutdown and power up until the load fault is removed. During this period, the average current flowing into the fault is significantly reduced. Once the fault is removed, the module automatically recovers and returns to normal operation.

6.3 Soft-Start Power-Up

The Auto-Track feature allows the power-up of multiple PTH modules to be directly controlled from the Track pin. However in a stand-alone configuration, or when the Auto-Track feature is not being used, the Track pin should be directly connected to the input voltage, V_{in} (see Figure 6).

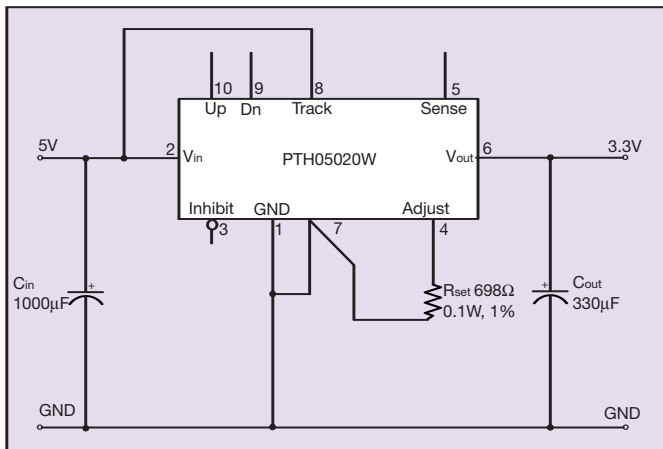
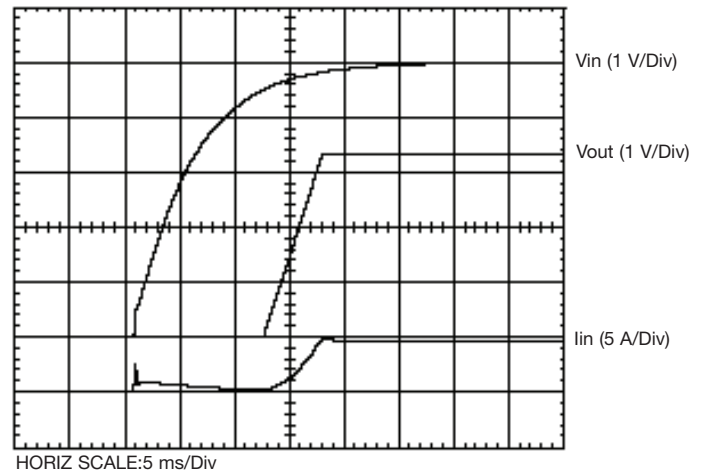

Figure 6 - Soft-Start Power-up

When the Track pin is connected to the input voltage the Auto-Track function is permanently disengaged. This allows the module to power up entirely under the control of its internal soft-start circuitry. When power up is under soft-start control, the output voltage rises to the set-point at a quicker and more linear rate.



HORIZ SCALE:5 ms/Div

Figure 7 - Power-up Characteristic

From the moment a valid input voltage is applied, the soft-start control introduces a short time delay (typically 5 ms to 10 ms) before allowing the output voltage to rise. The output then progressively rises to the module's setpoint voltage. Figure 7 shows the soft-start power-up characteristic of the 22 A output product (PTH05020W), operating from a 5 V input bus and configured for a 3.3 V output. The waveforms were measured with a 5 A resistive load, with Auto-Track disabled. The initial rise in input current when the input voltage first starts to rise is the charge current drawn by the input capacitors. Power-up is complete within 15 ms.

7. Feature Set

7.1 Adjusting the Output Voltage

The V_o adjust control (pin 4) sets the output voltage of the PTH03060W product. The adjustment range is from 0.8 Vdc to 2.5 Vdc. The adjustment method requires the addition of a single external resistor, R_{set} , that must be connected directly between the V_o Adjust and GND pins⁽¹⁾. Table 4 gives the preferred value for the external resistor for a number of standard voltages, along with the actual output voltage that this resistance value provides.

For other output voltages the value of the required resistor can either be calculated using the following formula, or simply selected from the range of values given in Table 5. Figure 8 shows the placement of the required resistor.

$$R_{set} = 10K \times \frac{0.8V}{V_{out} - 0.8V} - 2.49 \text{ k}\Omega$$

V_{out} Standard	R_{set} (Preferred Value)	V_{out} (Actual)
2.5 V	2.21 k Ω	2.502 V
2.0 V	4.12 k Ω	2.010 V
1.8 V	5.49 k Ω	1.803 V
1.5 V	8.87 k Ω	1.504 V
1.2 V	17.4 k Ω	1.202 V
1.0 V	36.5 k Ω	1.005 V
0.8 V	Open	0.8 V

Table 4 - Preferred Values of R_{set} for Standard Output Voltages

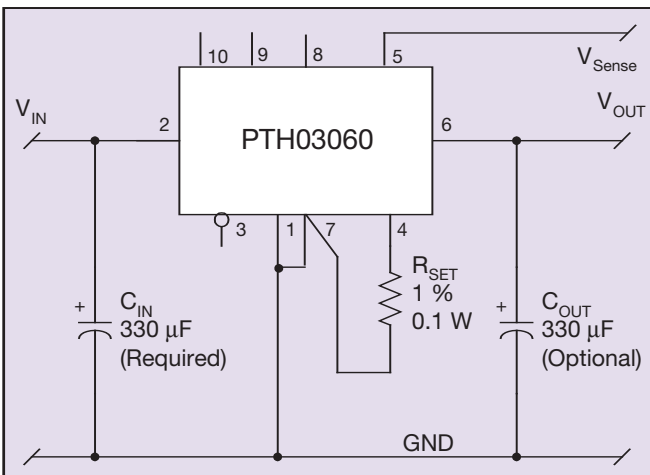

Figure 8 - Adjust Resistor Placement

OUTPUT VOLTAGE SET-POINT RESISTOR VALUES					
V_a Req'd	R_{set}	V_a Req'd	R_{set}	V_a Req'd	R_{set}
0.800	Open	1.225	16.3 k Ω	1.75	5.93 k Ω
0.825	318 k Ω	1.250	15.3 k Ω	1.80	5.51 k Ω
0.850	158 k Ω	1.275	14.4 k Ω	1.85	5.13 k Ω
0.875	104 k Ω	1.300	13.5 k Ω	1.90	4.78 k Ω
0.900	77.5 k Ω	1.325	12.7 k Ω	1.95	4.47 k Ω
0.925	61.5 k Ω	1.350	12.1 k Ω	2.00	4.18 k Ω
0.950	50.8 k Ω	1.375	11.4 k Ω	2.05	3.91 k Ω
0.975	43.2 k Ω	1.400	10.8 k Ω	2.10	3.66 k Ω
1.000	37.5 k Ω	1.425	10.3 k Ω	2.15	3.44 k Ω
1.025	33.1 k Ω	1.450	9.82 k Ω	2.20	3.22 k Ω
1.050	29.5 k Ω	1.475	9.36 k Ω	2.25	3.03 k Ω
1.075	26.6 k Ω	1.50	8.94 k Ω	2.30	2.84 k Ω
1.100	24.2 k Ω	1.55	8.18 k Ω	2.35	2.67 k Ω
1.125	22.1 k Ω	1.60	7.51 k Ω	2.40	2.51 k Ω
1.150	20.4 k Ω	1.65	6.92 k Ω	2.45	2.36 k Ω
1.175	18.8 k Ω	1.70	6.4 k Ω	2.50	2.22 k Ω
1.200	17.5 k Ω				

Notes:

- 1 Use a 0.1 W resistor, with a tolerance of 1% (or better). Place the resistor as close to the regulator as possible. Connect the resistor directly between pins 4 and 7 using dedicated PCB traces.
- 2 Never connect capacitors from V_o Adjust to either GND or V_{out} . Any capacitance added to the V_o Adjust pin will affect the stability of the regulator.

Table 5 - Output Voltage Set-point Resistor Values

7.2 Output ON/OFF Inhibit

For applications requiring output voltage ON/OFF control, each series of the PTH family incorporates an output Inhibit control pin. The inhibit feature can be used wherever there is a requirement for the output voltage from the regulator to be turned OFF.

The power modules function normally when the Inhibit pin is left open-circuit, providing a regulated output whenever a valid source voltage is connected to V_{in} with respect to GND. Figure 9 shows the typical application of the inhibit function. Note the discrete transistor (Q1). The Inhibit control has its own internal pull-up to $+V_{in}$ potential. The input is not compatible with TTL logic devices. An open-collector (or open-drain) discrete transistor is recommended for control.

Turning Q1 on applies a low voltage to the Inhibit control pin and disables the output of the module. If Q1 is then turned off, the module will execute a soft-start power-up sequence. A regulated output voltage is produced within 20 ms. Figure 10 shows the typical rise in both the output voltage and input current, following the turn-off of Q1. The turn off of Q1 corresponds to the rise in the waveform, Q1 V_{DS} . The waveforms were measured with a 5 A load.

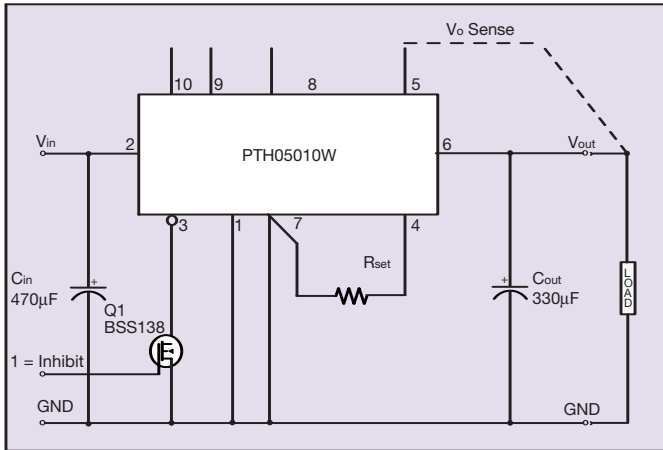

Figure 9 - Typical Application of the Inhibit Function

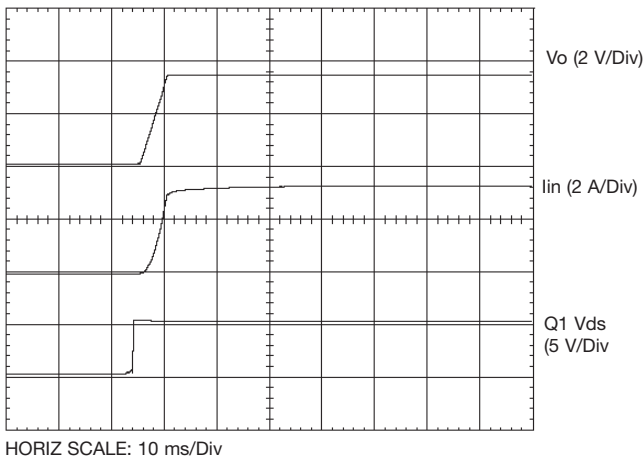

Figure 10 - Typical Rise in Output Voltage and Input Current

7.3 Pre-Bias Start-up Capability

Only selected products in the PTH family incorporate this capability. Consult Table 1 to identify which products are compliant.

A pre-bias startup condition occurs as a result of an external voltage being present at the output of a power module prior to its output becoming active. This often occurs in complex digital systems when current from another power source is backfed through a dual-supply logic component, such as an FPGA or ASIC. Another path might be via clamp diodes as part of a dual-supply power-up sequencing arrangement. A prebias can cause problems with power modules that incorporate synchronous rectifiers. This is because under most operating conditions, these types of modules can sink as well as source output current.

The PTH family of power modules incorporate synchronous rectifiers, but will not sink current during start-up⁽¹⁾, or whenever the Inhibit pin is held low. However, to ensure satisfactory operation of this function, certain conditions must be maintained⁽²⁾. Figure 12 shows an application demonstrating the pre-bias start-up capability. The start-up waveforms are shown in Figure 11. Note that the output current from the PTH03010 (I_o) shows negligible current until its output voltage rises above that backfed through diodes D1 and D2.

Note:

The pre-bias start-up feature is not compatible with Auto-Track. When the module is under Auto-Track control, it will sink current if the output voltage is below that of a back-feeding source. To ensure

a pre-bias hold-off one of two approaches must be followed when input power is applied to the module. The Auto-Track function must either be disabled⁽³⁾, or the module's output held off (for at least 50ms) using the Inhibit pin. Either approach ensures that the Track pin voltage is above the set-point voltage at start-up.

Notes:

- 1 Start-up includes the short delay (approx. 10 ms) prior to the output voltage rising, followed by the rise of the output voltage under the module's internal soft-start control. Startup is complete when the output voltage has risen to either the set-point voltage or the voltage at the Track pin, whichever is lowest.
- 2 To ensure that the regulator does not sink current when power is first applied (even with a ground signal applied to the Inhibit control pin), the input voltage must always be greater than the output voltage throughout the power-up and power-down sequence.
- 3 The Auto-Track function can be disabled at power up by immediately applying a voltage to the module's Track pin that is greater than its set-point voltage. This can be easily accomplished by connecting the Track pin to Vin

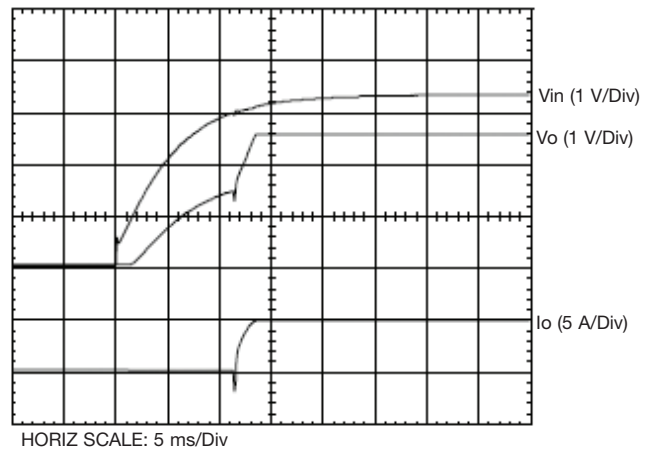

Figure 11 - Pre-Bias Start-up Waveforms

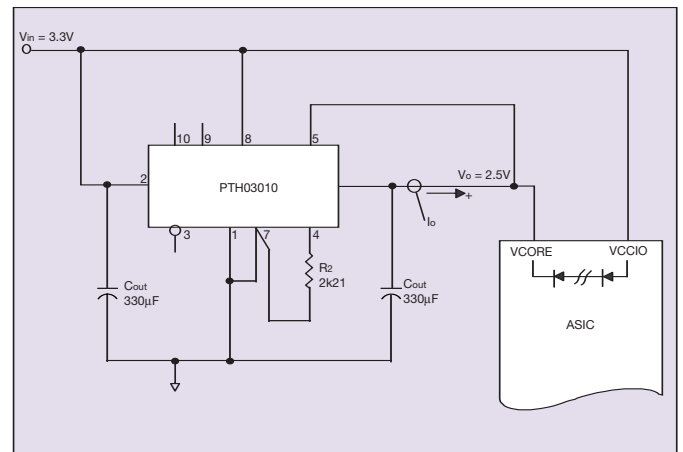

Figure 12 - Application Circuit Demonstrating Pre-Bias Start-up

7.4 Margin Up/Down Controls

The PTHxx060W, PTHxx010W, PTHxx020W, and PTHxx030W module series incorporate Margin Up and Margin Down control inputs. These controls allow the output voltage set point to be momentarily adjusted⁽¹⁾, either up or down, by a nominal 5%. This provides a convenient method for dynamically testing the operation of the load circuit over its power supply margin or range. The ±5% change is applied to the adjusted output voltage as set by the external resistor, R_{Set} at the V_O Adjust pin.

The 5% adjustment is made by driving the appropriate margin control input directly to the GND terminal⁽²⁾. A low-leakage open-drain device, such as a MOSFET or p-channel JFET is recommended for this purpose. Adjustments of less than 5% can also be accommodated by adding series resistors to the control inputs (see Figure 13). The value of the resistor can be selected from Table 6 or calculated using the following formula.

7.4.1 Up/Down Adjust Resistance Calculation

To reduce the margin adjustment to something less than 5%, series resistors are required (See R_D and R_U in Figure 13). For the same amount of adjustment, the resistor value calculated for R_D and R_U will be the same. The formulas is as follows.

Where Δ% = The desired amount of margin adjust in percent.

$$R_u \text{ or } R_d = \frac{499}{\Delta\%} - 99.8 \text{ k}\Omega$$

Notes

- 1 The Margin Up and Margin Down controls were not intended to be activated simultaneously. If they are their affects on the output voltage may not completely cancel, resulting in the possibility of a slightly higher error in the output voltage set point.
- 2 The ground reference should be a direct connection to the module GND at pin 7 (pin 1 for the PTHxx050). This will produce a more accurate adjustment at the load circuit terminals. The transistors Q1 and Q2 should be located close to the regulator.
- 3 The Margin Up and Margin Dn control inputs are not compatible with devices that source voltage. This includes TTL logic. These are analog inputs and should only be controlled with a true open-drain device (preferably a discrete MOSFET transistor). The device selected should have low off-state leakage current. Each input sources 8 μA when grounded, and has an open-circuit voltage of 0.8 V.

0% Adjust	R _U /R _D
5	0.0 Ω
4	24.9 kΩ
3	66.5 kΩ
2	150.0 kΩ
1	397.0 kΩ

Table 6 - Margin Up/Down Resistor Values

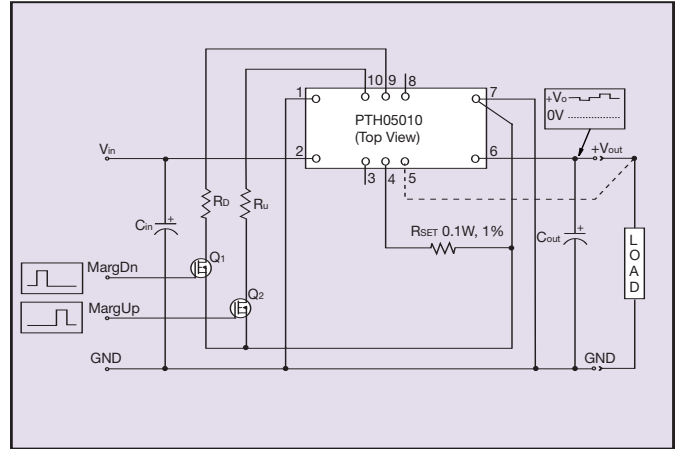

Figure 13 - Margin Up/Down Application Schematic

7.5 Remote Sense

The PTHxx010W, PTHxx020W, and PTHxx030W products incorporate an output voltage sense pin, V_O Sense. The V_O Sense pin should be connected to V_{out} at the load circuit (see datasheet standard application). A remote sense improves the load regulation performance of the module by allowing it to compensate for any 'IR' voltage drop between itself and the load. An IR drop is caused by the high output current flowing through the small amount of pin and trace resistance. Use of the remote sense is optional. If not used, the V_{out} Sense pin can be left open-circuit. An internal low-value resistor (15 Ω or less) is connected between the V_O Sense and V_{out}, ensures that the output voltage remains in regulation.

With the sense pin connected, the difference between the voltage measured directly between the V_{out} and GND pins, and that measured from V_{out} Sense to GND, is the amount of IR drop being compensated by the regulator. This should be limited to a maximum of 0.3 V.

Note: The remote sense feature is not designed to compensate for the forward drop of non-linear or frequency dependent components that may be placed in series with the converter output. Examples include OR-ing diodes, filter inductors, ferrite beads, and fuses. When these components are enclosed by the remote sense connection they are effectively placed inside the regulation control loop, which can adversely affect the stability of the regulator.

8. Thermal Information

8.1 Thermal Reference Points

The electrical operating conditions namely:

- Input voltage, V_{in}
- Output voltage, V_o
- Output current, I_o

determine how much power is dissipated within the converter. The following parameters further influence the thermal stresses experienced by the converter:

- Ambient temperature
- Air velocity
- Thermal efficiency of the end system application
- Parts mounted on system PCB that may block airflow
- Real airflow characteristics at the converter location

8.2 Safe Operating Area Curve

Thermal characterisation data is presented in the datasheet in a safe operating area curve format which is repeated here in Figure 14. The SOA curve shows the load current versus the ambient air temperature and velocity.

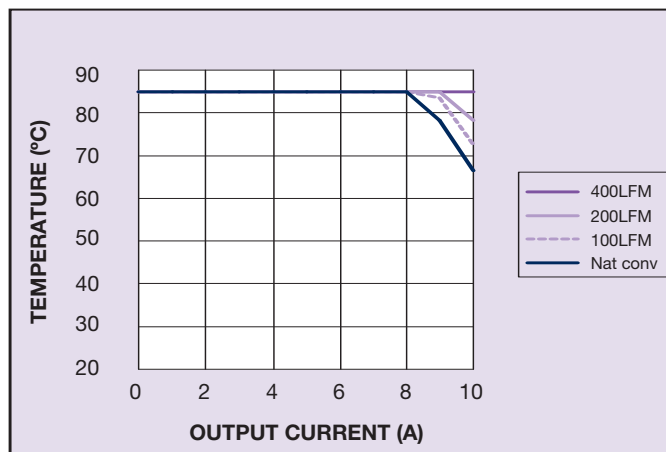

Figure 14 - Safe Operating Curve
PTH03060W $V_{out} = 2.5 V$

8.3 Thermal Test Set-up

All of the data was taken with the converter soldered to a test board which closely represents a typical application. The test board is a 1.6 mm, eight layer FR4 PCB with the inner layers consisting of 2 oz power and ground planes. The top and bottom layers contain a minimal amount of metalisation. A board to board spacing of 1 inch was used. The data represented by the 0 m/s curve indicate a natural convection condition i.e. no forced air. However, since the thermal performance is heavily dependent upon the final system application, the user needs to ensure the thermal reference point temperatures are kept within the recommended temperature rating. It is recommended that the thermal reference point temperatures are measured using either AWG #36 or #40 gauge thermocouples or an IR camera. In order to comply with stringent Artesyn derating criteria, the ambient temperature should never exceed 85 °C. Please contact Artesyn Technologies for further support.

9. Use in a Manufacturing Environment

9.1 Recommended Land Pattern

It is recommended that the customer uses a solder mask defined land pattern similar to that shown in Figures 15 and 16.

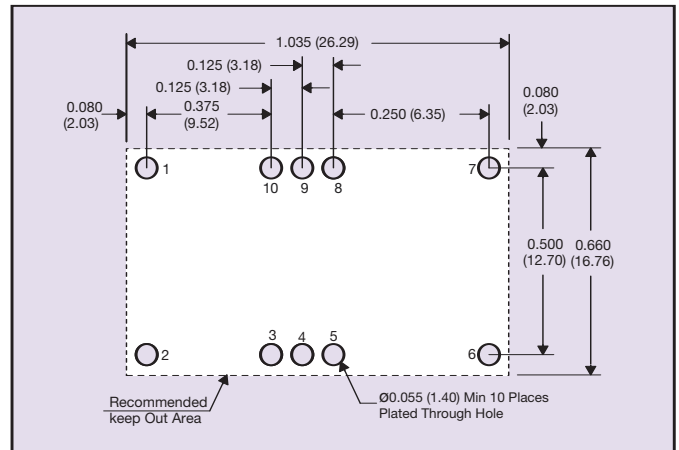

Figure 15 - Recommended Land Pattern (Through-Hole Model)

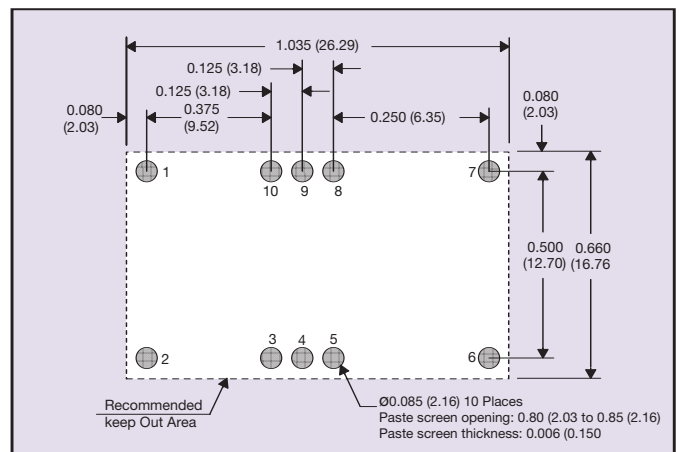

Figure 16 - Recommended Land Pattern (Surface Mount Model)

Power pin connection should utilize four or more vias to the interior power plane of 0.025 (0.63) I.D. per input, ground and output pin (or the electrical equivalent).

As a surface-mount power component, interconnection to internal power planes will typically be required. This is accomplished by placing a number of vias between the SMT pad and the relevant plane. The number and exact location of these vias should be determined based on electrical resistivity, current flow and thermal requirements.

10. Auto-Track™

10.1 Auto-Track™ Function

The Auto-Track function is unique to the PTH family, and is available with the all “Point-of-Load Alliance” (POLA) products. Auto-Track was designed to simplify the amount of circuitry required to make the output voltage from each module power up and power down in sequence. The sequencing of two or more supply voltages during power up is a common requirement for complex mixed-signal applications, that use dual-voltage VLSI ICs such as DSPs, micro-processors, and ASICs.

10.2 How Auto-Track™ Works

Auto-Track works by forcing the module’s output voltage to follow a voltage presented at the Track control pin. This control range is limited to between 0 V and the module’s set-point voltage. Once the track-pin voltage is raised above the set-point voltage, the module’s output remains at its set-point⁽¹⁾. As an example, if the Track pin of a 2.5 V regulator is at 1 V, the regulated output will be 1 V. But if the voltage at the Track pin rises to 3 V, the regulated output will not go higher than 2.5 V.

When under track control, the regulated output from the module follows the voltage at its Track pin on a volt-for-volt basis. By connecting the Track pin of a number of these modules together, the output voltages will follow a common signal during power-up and power-down. The control signal can be an externally generated master ramp waveform, or the output voltage from another power supply circuit⁽³⁾. For convenience the Track control incorporates an internal RC charge circuit. This operates off the module’s input voltage to provide a suitable rising voltage ramp waveform.

10.3 Typical Application

The basic implementation of Auto-Track allows for simultaneous voltage sequencing of a number of Auto-Track compliant modules. Connecting the Track control pins of two or more modules forces the Track control of all modules to follow the same collective RC ramp waveform, and allows them to be controlled through a single transistor or switch; Q1 in Figure 17.

To initiate a power-up sequence the Track control must first pulled to ground potential. This should be done at or before input power is applied to the modules, and then held for at least 10ms thereafter. This brief period gives the modules time to complete their internal soft-start initialization, which enables them to produce an output voltage.

Applying a logic-level high signal to the circuit’s On/Off Control turns Q1 on and applies a ground signal to the Track control. After completing their internal soft-start initialization, the output of all modules will remain at zero volts while Q1 is on. 10ms after a valid input voltage has been applied to all modules, Q1 can be turned off. This allows the track control voltage to automatically rise toward to the modules’ input voltage. During this period the output voltage of each module will rise in unison with other modules, to its respective set-point voltage.

Figure 18 shows the output voltage waveforms from the circuit of Figure 17 after the On/Off Control is set from a high to a low-level voltage. The waveforms, V_{o1} and V_{o2} represent the output voltages from the two power modules, U1 (3.3 V) and U2 (1.8 V) respectively. V_{o1} and V_{o2} are shown rising together to produce the desired simultaneous power-up characteristic.

The same circuit also provides a power-down sequence. Power down is the reverse of power up, and is accomplished by lowering the track control voltage back to zero volts. The important constraint is that a valid input voltage must be maintained until the power down is complete. It also requires that Q1 be turned off relatively slowly. This is so that the Track control voltage does not fall faster than Auto-Track’s slew rate capability, which is 1 V/ms. The components R1 and C1 in Figure 17 limit the rate at which Q1 can pull down the Track control voltage. The values of 100 k Ω and 0.1 μ F correlate to a decay rate of about 0.17 V/ms.

The power-down sequence is initiated with a low-to-high transition at the On/Off Control input to the circuit. Figure 19 shows the power-down waveforms. As the Track control voltage falls below the nominal set-point voltage of each power module, then its output voltage decays with all the other modules under Auto-Track control.

Notes on the Use of Auto-Track™

- 1 The Track pin voltage must be allowed to rise above the module’s set-point voltage before the module can regulate at its adjusted set-point voltage.
- 2 The Auto-Track function will track almost any voltage ramp during power up, and is compatible with ramp speeds of up to 1 V/ms.
- 3 The absolute maximum voltage that may be applied to the Track pin is V_{in} .
- 4 The module will not follow a voltage at its Track control input until it has completed its soft-start initialization. This takes about 10ms from the time that the module has sensed that a valid voltage has been applied its input. During this period, it is recommended that the Track pin be held at ground potential.
- 5 The module is capable of both sinking and sourcing current when following a voltage at its Track pin. Therefore startup into an output prebias is not supported during Auto-Track control. Note: A pre-bias holdoff is not necessary when all supply voltages rise simultaneously under the control of Auto-Track.
- 6 The Auto-Track function can be disabled by connecting the Track pin to the input voltage (V_{in}). With Auto-Track disabled, the output voltage will rise at a quicker and more linear rate after input power is applied.

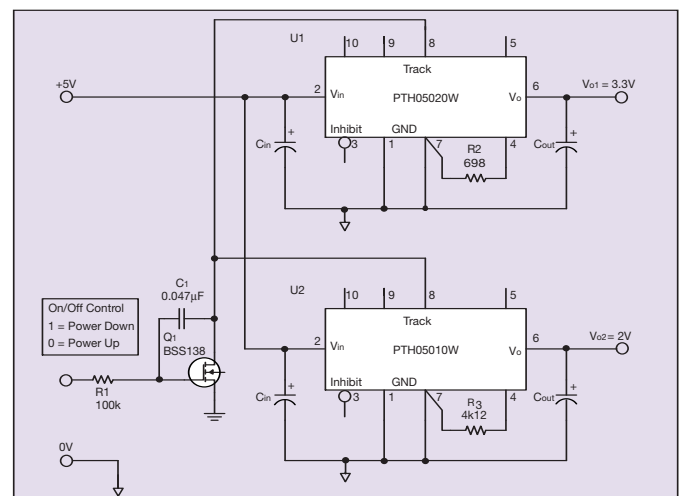

Figure 17 - Sequenced Power Up and Power Down Using Auto-Track

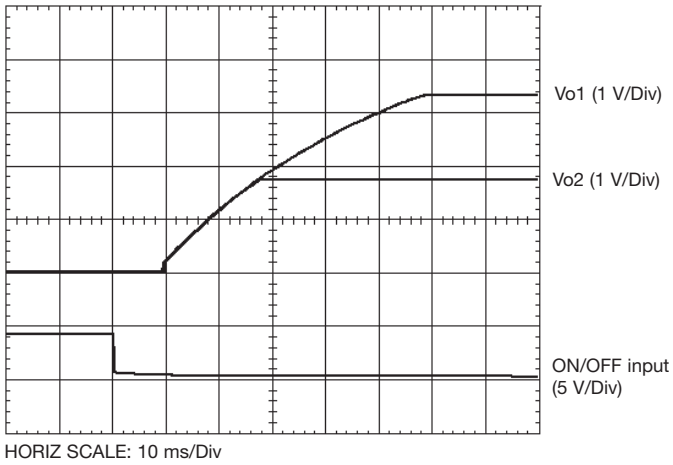

Figure 18 - Power Up with Auto-Track Control

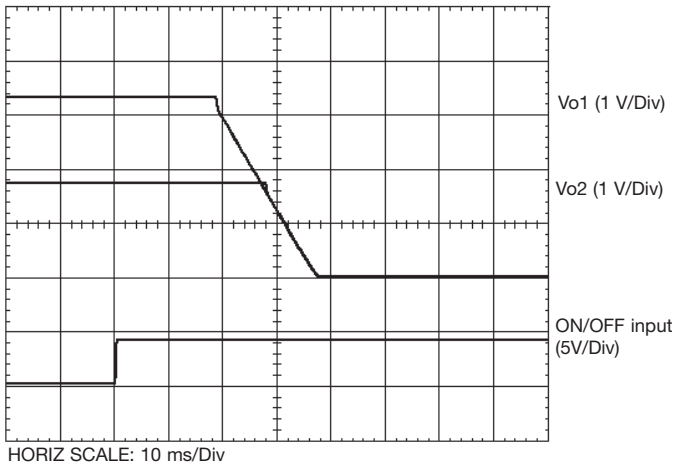

Figure 19 - Power Down with Auto-Track Control

The pre-bias start-up feature is not compatible with Auto-Track™. This is because when the module is under Auto-Track™ control, it is fully active and will sink current if the output voltage is below that of a back-feeding source. Therefore to ensure a pre-bias hold-off, one of the following two techniques must be followed when input power is first applied to the module. The Auto-Track™ function must either be disabled, or the module's output held off using the Inhibit pin.

Application Note © Artesyn Technologies® 2006

The information and specifications contained in this Application Note are believed to be correct at time of publication. However, Artesyn Technologies accepts no responsibility for consequences arising from printing errors or inaccuracies. The information and specifications contained or described herein are subject to change in any manner at any time without notice. No rights under any patent accompany the sale of any such product(s) or information contained herein.