

Series 5
IN 5/5 IMPAC Pyrometer

MANUAL



Confidential Information

The material contained herein consists of information that is the property of LumaSense Technologies, an Advanced Energy Company, and intended solely for use by the purchaser of the equipment described in this manual.

All specifications are subject to change without notice. Changes are made periodically to the information in this publication, and these changes will be incorporated in new editions.

LumaSense Technologies prohibits the duplication of any portion of this manual or the use thereof for any purpose other than the operation or maintenance of the equipment described in this manual, without the express written permission of LumaSense Technologies or Advanced Energy Industries, Inc.

Any unauthorized use of this manual or its contents is strictly prohibited.

Copyright

© 2019 LumaSense Technologies, Inc. All Rights Reserved. LumaSense Technologies, Inc., a subsidiary of Advanced Energy Industries, Inc.

Trademarks

IMPAC is a trademark of LumaSense Technologies.

All other trademarks are trademarks, registered trademarks, and/or service marks of their respective holders.

Service Centers

LumaSense Technologies, Inc.

North America

Sales & Service

Santa Clara, CA, USA

Ph: +1 800 631 0176

Ph: +1 408 727 1600

Fax: +1 408 727 1677

LumaSense Technologies GmbH

Other Than North America

Sales & Support

Frankfurt, Germany

Ph: +49 (0) 69 97373 0

Fax: +49 (0) 69 97373 167

Global and Regional Centers

Our Headquarters

LumaSense Technologies, Inc.

Santa Clara, CA, USA

Ph: +1 800 631 0176

Fax: +1 408 727 1677

Americas, Australia, & Other Asia

LumaSense Technologies, Inc.

Santa Clara, CA, USA

Ph: +1 800 631 0176

Fax: +1 408 727 1677

Europe, Middle East, Africa

LumaSense Technologies GmbH

Frankfurt, Germany

Ph: +49 (0) 69 97373 0

Fax: +49 (0) 69 97373 167

France

LumaSense Technologies Sarl

Erstein, France

Ph: +33 3 8898 9801

Fax: +33 3 8898 9732

India

LumaSense Technologies, India

Mumbai, India

Ph: + 91 22 67419203

Fax: + 91 22 67419201

China

LumaSense Technologies, China

Shanghai, China

Ph: +86 133 1182 7766

Ph: +86 21 5899 7915

E-mail info@lumasenseinc.com
 support@lumasenseinc.com
 eusupport@lumasenseinc.com

Website <http://www.lumasenseinc.com>

Part No 3 869 019

Revision -

January 2019

Contents

1	General	5
1.1	Information about the user manual	5
1.1.1	Legend.....	5
1.1.2	Terminology.....	5
1.2	Safety	5
1.2.1	Electrical connection.....	6
1.3	Limit of liability and warranty	6
1.4	Unpacking the Instrument	6
1.5	Service Request, Repair, or Support	7
1.6	Shipments to LumaSense for Repair	7
1.7	Transport, packaging, storage	8
1.8	Disposal / decommissioning	8
2	Introduction	9
2.1	Appropriate use	9
2.2	Scope of delivery	9
2.3	Technical data	9
2.4	Dimensions	11
2.5	Physical User Interface	11
2.6	Accessories (Optional)	12
3	Controls and Connections	13
3.1	Electrical Installation	13
3.2	Pin assignment at the pyrometer	14
3.3	Optics	14
3.4	Alignment of the instrument	15
4	Settings / Parameter Descriptions	17
4.1	Factory settings	17
4.2	Instrument settings	17
4.3	Emissivity (EMI)	17
4.4	Response time / exposure time (t_{90})	19
4.5	Avoiding reading errors caused by faulty assembly	19
5	Maintenance	21
5.1	Safety	21
5.2	Service	21
6	Reference numbers	23
6.1	Reference numbers instrument	23
6.2	Reference numbers accessories	23

7 Troubleshooting.....	25
Index.....	27

1 General

1.1 Information about the user manual

Congratulations on choosing the high quality and highly efficient IMPAC pyrometer.

This manual provides important information about the instrument and can be used as a work of reference for installing, operating, and maintaining your IMPAC pyrometer. It is important that you carefully read the information contained in this manual and follow all safety procedures before you install or operate the instrument.

To avoid handling errors, keep this manual in a location where it will be readily accessible.

1.1.1 Legend



Note: The note symbol indicates tips and useful information in this manual. All notes should be read to effectively operate the instrument.



Warnings and Cautions: The general warnings and cautions symbol signifies the potential for bodily harm or damage to equipment.

MB Shortcut for Temperature range (in German: **Messbereich**).

1.1.2 Terminology

The terminology used in this manual corresponds to the VDI- / VDE-directives 3511, Part 4.

1.2 Safety

This manual provides important information on safely installing and operating the IMPAC pyrometer. Several sections of this manual provide safety warnings to avert danger. These safety warnings are specified with a warning symbol. You must read and understand the contents of this manual before operating the instrument even if you have used similar instruments or have already been trained by the manufacturer.

It is also important to continually pay attention to all labels and markings on the instrument and to keep the labels and markings in a permanent readable condition.



Warning: The pyrometer is only to be used as described in this manual. It is recommended that you only use accessories provided by the manufacturer.

In addition, signs and markings on the device are to be observed and maintained in legible condition.

1.2.1 Electrical connection

Follow common safety regulations for mains voltage (e.g. 230 or 115 V AC) connecting additional devices operating with this mains voltage (e.g. transformers). Touching mains voltage can be mortal. A non-expert connection and mounting can cause serious health or material damages.

Only qualified specialists are allowed to connect such devices to the mains voltage.

1.3 Limit of liability and warranty

All general information and notes for handling, maintenance, and cleaning of this instrument are offered according to the best of our knowledge and experience.

LumaSense Technologies is not liable for any damages that arise from the use of any examples or processes mentioned in this manual or in case the content of this document should be incomplete or incorrect. LumaSense Technologies reserves the right to revise this document and to make changes from time to time in the content hereof without obligation to notify any person or persons of such revisions or changes.

All instruments from LumaSense Technologies have a regionally effective warranty period. Please check our website at <http://info.lumasenseinc.com/warranty> for up-to-date warranty information. This warranty covers manufacturing defects and faults, which arise during operation, only if they are the result of defects caused by LumaSense Technologies.

The warranty is VOID if the instrument is disassembled, tampered with, altered, or otherwise damaged without prior written consent from LumaSense Technologies; or if considered by LumaSense Technologies to be abused or used in abnormal conditions. There are no user-serviceable components in the instrument.

1.4 Unpacking the Instrument

Thoroughly inspect the instrument upon delivery to purchaser. Check all materials in the container against the enclosed packing list. LumaSense Technologies cannot be responsible for shortages against the packing list unless a claim is immediately filed with the carrier. The customer must complete final claim and negotiations with the carrier.

Save all packing materials, including the carrier's identification codes, until you have inspected the pyrometer and find that there is no obvious or hidden damage. Before shipment, the pyrometer was examined and has been tested. If you note any damage or suspect damage, immediately contact the carrier and LumaSense Technologies, Inc.

1.5 Service Request, Repair, or Support

Contact LumaSense Technologies Technical Support in case of a malfunction or service request. Provide clearly stated details of the problem as well as the instrument model number and serial number. Upon receipt of this information, Technical Support will attempt to locate the fault and, if possible, solve the problem over the telephone.

If Technical Support concludes that the instrument must be returned to LumaSense Technologies for repair, they will issue a Return Material Authorization (RMA) number.

Return the instrument upon receipt of the RMA number, transportation prepaid. Clearly indicate the assigned RMA number on the shipping package exterior. Refer to Section **1.6, Shipments to LumaSense for Repair**, for shipping instructions.

Technical Support can be contacted by telephone or email:

Santa Clara, California

- Telephone: +1 408 727 1600 or +1 800 631 0176
- Email: support@lumasenseinc.com

Frankfurt, Germany

- Telephone: +49 (0) 69 97373 0
- Email: eusupport@lumasenseinc.com

Erstein, France

- Telephone +33 (0)3 88 98 98 01
- Email: eusupport@lumasenseinc.com

1.6 Shipments to LumaSense for Repair

All RMA shipments of LumaSense Technologies instruments are to be prepaid and insured by way of United Parcel Service (UPS) or preferred choice. For overseas customers, ship units air-freight, priority one.

The instrument must be shipped in the original packing container or its equivalent. LumaSense Technologies is not responsible for freight damage to instruments that are improperly packed.

Contact us to obtain an RMA number (if Technical Support has not already assigned one). Clearly indicate the assigned RMA number on the shipping package exterior.

Send RMA Shipments to your nearest technical service center:

Customers in **North America** should send RMA Shipments to:

Santa Clara, California

LumaSense Technologies, Inc.
3301 Leonard Court
Santa Clara, CA 95054 USA
Telephone: +1 408 727 1600
+1 800 631 0176

Email: support@lumasenseinc.com

All other customers should send RMA Shipments to:

Frankfurt, Germany

LumaSense Technologies GmbH
Kleyerstr. 90
60326 Frankfurt
Germany
Telephone: +49 (0)69-97373 0

Email: eusupport@lumasenseinc.com

1.7 Transport, packaging, storage

With faulty shipping, the instrument can be damaged or destroyed. To transport or store the instrument, please use the original box or a box padded with sufficient shock-absorbing material. For storage in humid areas or shipment overseas, the device should be placed in welded foil (ideally along with silica gel) to protect it from humidity.

The pyrometer is designed for a storage temperature of -20 to 70 °C with non-condensing conditions. Storing the instrument out of these conditions can cause damage or result in malfunction of the pyrometer.

1.8 Disposal / decommissioning

Inoperable IMPAC pyrometers must be disposed of in compliance with local regulations for electro or electronic material.

2 Introduction

2.1 Appropriate use

The IN 5/5 is a stationary infrared thermometer for non-contact temperature measurement of glass and quartz glass surfaces with temperature ranges between 100 and 2500 °C.

For optimal match of the instrument to the application the pyrometers are equipped ex works with the desired optics (for every instrument 3 different optics are available).

2.2 Scope of delivery

Instrument with selected optic, works certificate, operation manual.



Note: The connection cable is not included with the instrument and must be ordered separately (see section 7, **Reference numbers**).

2.3 Technical data

Temperature Ranges:	100 ... 600 °C (MB 6) 200 ... 800 °C (MB 8) 100 ... 1300 °C (MB 13) 400 ... 2500 °C (MB 25) (Further MB on request)
IR Detector:	Thermopile
Data Handling:	Digital
Spectral Range:	5.14 µm
Power Supply:	24 V DC (10 ... 30 V)
Power Consumption:	Max. 20 mA
Load:	Max. 700 Ω @ 24 V (max. 100 Ω @ 12 V)
Response Time t_{90} :	0.08 s; adjustable in the pyrometer: 0.5 s; 1 s; 2 s; 5 s
Analog Output:	4 ... 20 mA (linear)
Parameters:	Adjustable on the pyrometer: Emissivity, Exposure time
Emissivity ε :	0.2 ... 1 adjustable
Measurement Uncertainty: Dependent on object temperature T and ambient temperature T_{amb} ($\varepsilon = 1$, $t_{90} = 1$ s)	T < 1300 °C: 0.6% of reading in °C or 2 °C ($T_{amb} = 15 ... 30$ °C) ¹ 1% of reading in °C or 1.5 °C ($T_{amb} = 0 ... 15$ or $30 ... 63$ °C) ¹ T = 1300 ... 1800 °C: 0.8% of reading in °C ($T_{amb} = 15 ... 30$ °C) 1.2% of reading in °C ($T_{amb} = 0 ... 15$ or $30 ... 63$ °C) T = 1800 ... 2500 °C: 1% of reading in °C ($T_{amb} = 15 ... 30$ °C) 1.4% of reading in °C ($T_{amb} = 0 ... 15$ or $30 ... 63$ °C)
Repeatability: ($\varepsilon = 1$, $t_{90} = 1$ s)	0.3% of reading in °C or 0.6 °C ¹

Noise Equivalent Temperature Difference (NETD): ($\epsilon = 1, T_{amb} = 23\text{ °C}$)	@ $t_{90} = 80\text{ ms}$: 0.7 °C (@ 110 °C measuring temperature) @ $t_{90} = 1\text{ s}$: 0.4 °C (@ 110 °C measuring temperature)
Protection Class:	IP65 (DIN 40050)
Ambient Temperature:	0 ... 70 °C
Storage Temperature:	-20 ... 70 °C
Rel. Humidity:	Non-condensing conditions
Weight:	Approx. 410 g
Housing:	Stainless steel
Operating Position:	Any
Optics:	Zinc-Sulfide lens (ZnS)
CE-label:	According to EU directives about electromagnetic immunity

¹Whichever value is greater. The instrument must be at a const. amb. temp. for min. 15 min. and has to be connected to the power supply.

Note: The determination of the technical data of this pyrometer is carried out in accordance with VDI/VDE directive IEC TS 62942-2, "Determination of the technical data for radiation thermometers".



The calibration / adjustment of the instruments was carried out in accordance with VDI/VDE directive "Temperature measurement in industry, Radiation thermometry, Calibration of radiation thermometers", VDI/VDE 3511, Part 4.4.

For additional details on this directive, see <http://info.lumasenseinc.com/calibration> or order the directive from "Beuth Verlag GmbH" in D-10772 Berlin, Germany.

2.4 Dimensions

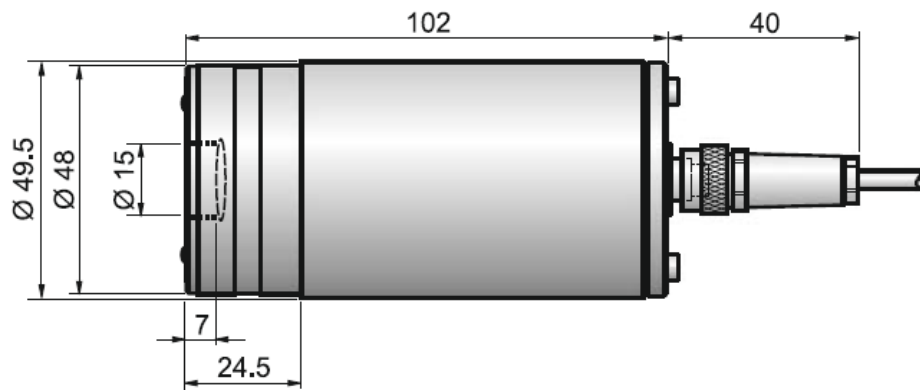

2.5 Physical User Interface

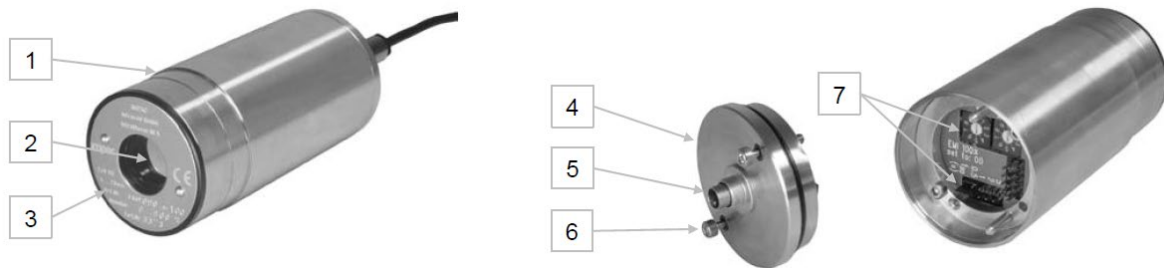

- 1 Stainless steel housing
- 2 Optics
- 3 Type label
- 4 Rear panel

- 5 Electrical connection
- 6 Fixing screws for rear panel
- 7 Settings at the pyrometer

2.6 Accessories (Optional)

Numerous accessories guarantee easy installation of the pyrometer. The following overview shows a selection of suitable accessories. You can find the entire accessory program with all reference numbers in Chapter 7, **Reference numbers**.

Mounting:

For easy mounting and aligning the pyrometer to the measured object an adjustable mounting angle is available.



Mounting angle

Cooling:

The completely covered water cooling jacket made from stainless steel protects the pyrometer if exposed to a hot environment. It is designed for ambient temperatures up to 180 °C.



Water cooling jacket with integrated air purge

Miscellaneous:

The air purge protects the lens from contamination with dust and moisture. It has to be supplied with dry and oil-free pressurized air and generates an air stream shaped like a cone.

The pyrometer can be easily fixed on a vacuum chamber with the KF 16 vacuum support with sighting window.



Air purge



Vacuum support

Display:

For temperature indication of the pyrometer IMPAC offers several digital displays.



Digital display
DA 6000

3 Controls and Connections

3.1 Electrical Installation

The pyrometers are powered by 24 V DC nominal (possible range: 10 ... 30 V). When connecting the device to the power supply ensure correct polarity. The power consumption (in this case 4 ... 20 mA) is also the measuring signal. The instrument doesn't need any time for starting or preheating and is immediately ready for operation.

To switch off the instrument, interrupt the power supply or unplug the electrical connector.

To meet the electromagnetic requirements (EMV), a shielded connecting cable must be used. The shield of the connecting cable has to be connected only on the pyrometer's side. On side of the power supply (switch board) the shield must be open to avoid ground loops. IMPAC offers connecting cables, they are not part of standard scope of delivery (see Chapter 7, **Reference Numbers**).

Example for wiring using a digital display with integrated power supply:

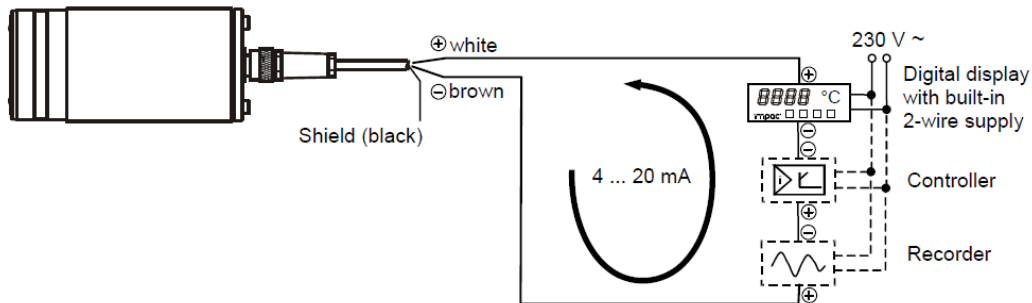

Example for wiring using an external power supply:

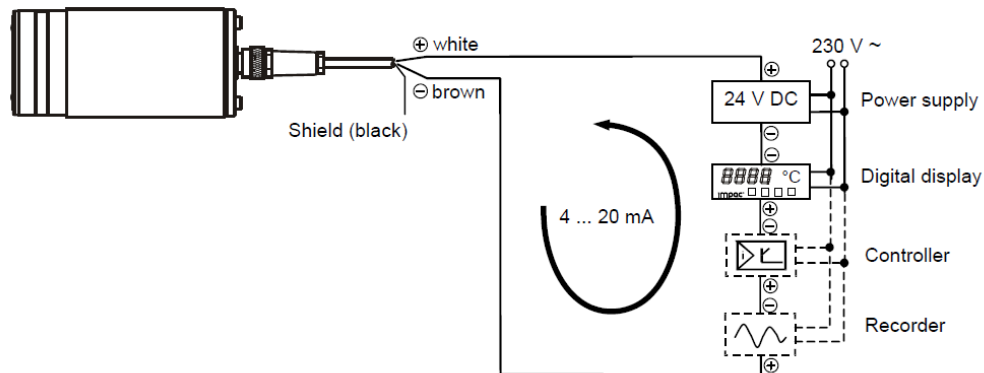

Note: Additional analyzing instruments, e.g. controllers, recorders, etc can be connected in series as shown in drawing above.

3.2 Pin assignment at the pyrometer

Pin	Cable Color	Connection
1	white	+24 V DC (10 ... 30 V)
2	brown	0 V
3	black	Shield

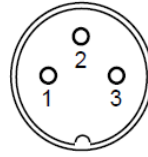

Instrument's plug:
3 pin flange connector

3.3 Optics

The pyrometers are equipped ex works with one of the following optics. These lenses are focusing to certain distances. In these distances each lens achieves its smallest spot size. The spot size will enlarge in any other distance (shorter or longer). Please notice that the measuring object must be as least as big as the spot size.

The name of the optics (e.g. optics 300) shows the measuring distance in mm (e.g. 300 mm, measured from the front of the lens) in which it has the smallest spot size (e.g. 6 mm).

The following drawings show the size of the spots in mm in dependence of the measuring distance. Values between the mentioned data can be calculated by interpolation. The spot size for measuring distance 0 is the aperture diameter D of the optics.

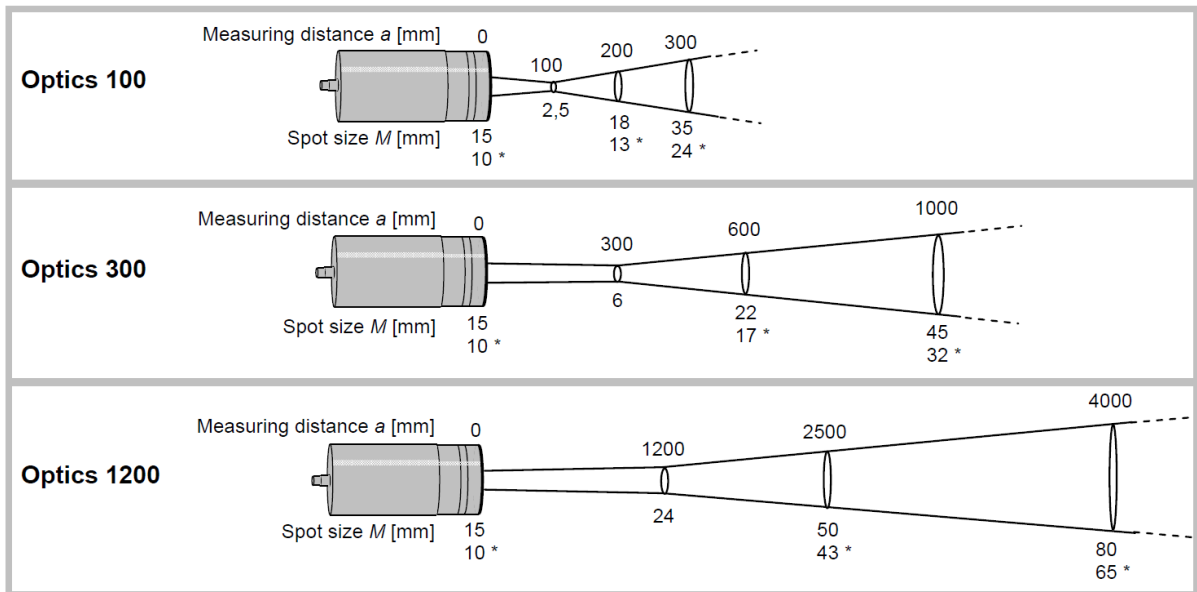

*Data based on the IN 5/5, MB 25.



Note: Please note that the optical profiles show nominal dimensions. The spot size diameter or the focal distance may be slightly different due to lens tolerances.

Spot sizes for intermediate distances, that are not shown on the optical profiles, may be calculated using the following formula:

$$M_2 = \frac{a_2}{a}(M - D) + D$$

$$M_1 = \frac{a_1}{a}(M + D) - D$$

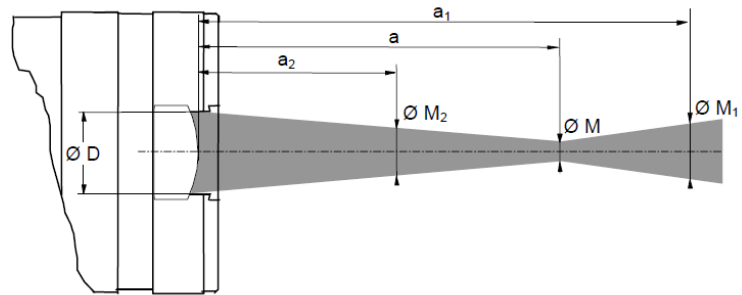

3.4 Alignment of the instrument

For exact measurement of the object temperature the pyrometer must be aligned correctly onto the object. The instruments are not equipped with a sighting so that the aligning must be done thermally. When measuring a hot object in front of a cooler background, it usually suffices to align the pyrometer to achieve the highest temperature reading.

To ensure consistent document formatting, this page was intentionally left blank.

4 Settings / Parameter Descriptions

4.1 Factory settings

Emissivity (**EMI**) = 100%

Exposure time (**t₉₀**) = 0.08 s

4.2 Instrument settings

The emissivity of the measuring object and the instrument's exposure time can be set via controls in the pyrometer housing.

The controls can be accessed by removing the rear panel in the following way:

1. Disconnect the electrical connection.
2. Unscrew the rear screws with a 2.5 mm allen screw.
3. Take the cover off, making sure it remains straight (without bending or twisting it).



Note: Please make sure that the pyrometer is not contaminated while open.

Assembling: When reassembling the cover, insert it carefully into the guide pins and then fasten it with the screws. The connector cable can now be plugged in.

4.3 Emissivity (EMI)

For a correct measurement it is necessary to adjust the emissivity. This emissivity is the relationship between the emission of a real object and the emission of a black body radiation source (this is an object which absorbs all incoming rays and has an emissivity of 100%) at the same temperature.

Different materials have different emissivities ranging between 0% and 100% (settings at the pyrometer between 20 and 100%). Additionally, the emissivity is depending on the surface condition of the material, the spectral range of the pyrometer and the measuring temperature. The emissivity setting of the pyrometer has to be adjusted accordingly. Typical emissivity values of various common materials for the two spectral ranges of the instruments are listed below. The tolerance of the emissivity values for each material is mainly dependent on the surface conditions. Rough surfaces have higher emissivities.

Settings:

100%
:
20%



Note: The minimum emissivity setting for the pyrometer is 20%!

The settings will be done via the rotary switch.

Setting examples:

EMI = 100%:

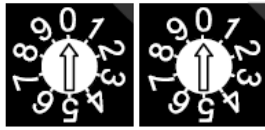

EMI = 85%:

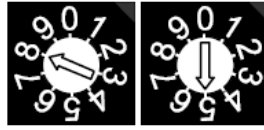

Rotary switch
for emissivity
adjustment



Note: If the emissivity is set to an incorrect value (below 20%) the instrument will automatically utilize an emissivity value of 100%. The setting 00 is interpreted as EMI = 100%.

Measuring object	EMI (@ 8 ... 14 μm)
"Black body furnace"	100%
Human skin	98%
Black dull varnish	95%
Carbon soot	95%
Wood	80 ... 92%
Paper	92 ... 95%
Asphalt	85%
Glass / quartz glass	72 ... 87%
Textile	75 ... 95%
Graphite	75 ... 92%
Cement	90%
Water	95%

Measuring object	EMI (@ 8 ... 14 μm)	
Brickwork	85... 95%	
Fire clay		
Rubber		
Porcelain		
Ceramics		
Varnish		
Plaster		
Oil paint		
Steel (oxidized)		60 ... 80%
Steel (smooth)		10 ... 30%
Aluminum (smooth)	2 ... 15%	
Aluminum (anodized)	90%	

Measuring object	EMI (@ 5.14 μm)
Glass / quartz glass	97%

One way to determine an accurate emissivity value for a material is to make a comparison measurement as follows: If possible, coat a portion of the object with dull black paint or carbon soot. Paint and carbon soot have high emissivities (95%) and take on the same temperature as the object. Measure the temperature of the painted area with the emissivity control set to 95%. Then measure the temperature of an adjacent unpainted area of the object and adjust the emissivity until the pyrometer displays the same temperature.

4.4 Response time / exposure time (t_{90})

The exposure time t_{90} is the time interval from the start of measurement up to the respective change in the output signal (4 ... 20 mA) which is the time taken to reach 90% of the recorded temperature difference.

The exposure time is changed by adjusting the jumper position. In the open position shown in the diagram on the left, the response time is 0.08 s.

For alternative settings ($t_{90} = 0.5$ s, 1 s, 2 s or 5 s) select the respective jumper position.

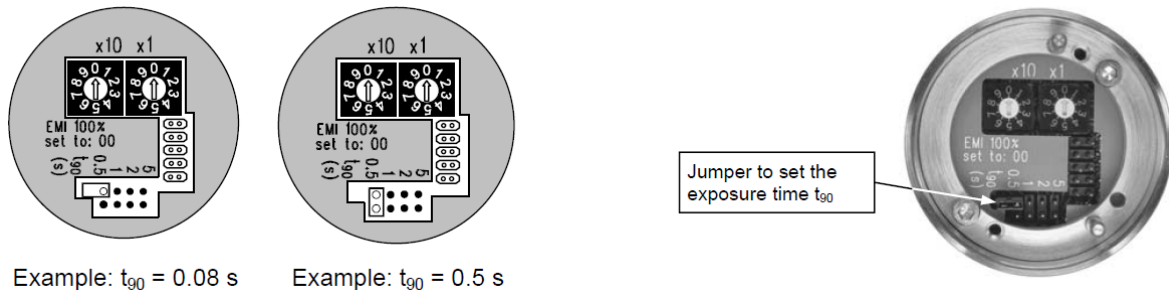

Longer exposure times are useful when measuring objects with fluctuating temperatures.

4.5 Avoiding reading errors caused by faulty assembly

To avoid reading errors, please note the following points when mounting the pyrometer:

1. The diameter of the measuring object cannot be smaller than the pyrometer's spot size (see section **3.3, Optics**).
2. A source of radiation behind or around the measuring object can influence the result. If the object is transparent or partly transparent another material behind the object could transmit its radiation to the pyrometer as well. In this case the location of the pyrometer should be changed, or, if the background radiation remains constant it can be compensated for by changing the emissivity setting respectively.
3. Please take into account that radiation, from other hot materials around the measured object, can be reflected by these materials and influence the result. If the measured object has a low emissivity, the temperature measured will be mainly that from the reflected object - not from the intended measured object itself. To prevent ambient radiation from reaching the spot area, a mounting tube should be used.

The mounting tube should be placed as near as possible to the measured object so that the tube's shadow blocks out all the ambient radiation from the side.

To ensure consistent document formatting, this page was intentionally left blank.

5 Maintenance

5.1 Safety



Attention during pyrometer services: Should the pyrometer be integrated in a running machine process the machine has to be switched off and secured against restart before servicing the pyrometer.

5.2 Service

The pyrometer does not have any parts which require regular service, only the lens has to be kept clean. The lens can be cleaned with a soft cloth in combination with alcohol (do not use acid solutions or dilution).

Also, standard cloths for cleaning glasses or photo objectives can be used.

To ensure consistent document formatting, this page was intentionally left blank.

6 Reference numbers

6.1 Reference numbers instrument

Type	Optics	Temperature Range ¹	Reference Number
IN 5/5	When ordering please select one optics (optics a = 100, 300, or 1200)	100 ... 600 °C	3 869 110
		200 ... 800 °C	3 869 120
		100 ... 1300 °C	3 869 130
		400 ... 2500 °C	3 869 140

¹Other temperature ranges on request.

Scope of delivery: Instrument with selected optic, works certificate, operation manual.

Ordering details: A connection cable is not included with the instrument and has to be ordered separately.

6.2 Reference numbers accessories

3 820 ...

Connection cable for IN 5/5:

2 m	5 m	10 m	15 m	30 m
... 210	... 560	... 570	... 580	... 590

3 852 290	Power supply NG DC (100 ... 240 V AC ⇒ 24 V DC, 1 A)
3 852 540	Power supply NG 0D (85 ... 265 V AC ⇒ 24 V DC, 600 mA)
3 890 650	DA 4000: LED digital display, 2 limit switches, 230 V AC
3 891 220	DA 4000: LED digital display, 2 limit switches, 115 V AC
3 890 520	DA 6000: LED digital display, digital and analog input, 2 limit switches, maximum value storage, analog output, RS232
3 890 530	DA 6000 with RS485
3 826 510	PI 6000: programmable PID controller
3 834 210	Adjustable mounting support
3 835 160	Air purge unit
3 835 440	Air purge unit, stainless steel
3 837 230	Water cooling jacket (heavy design) with integrated air purge unit (metric mounting threads)
5 837 230	(Same with UNC mounting threads)
3 837 340	Heavy water cooling jacket with protection window
3 837 370	Water cooling jacket (lightweight design) with integrated air purge unit (metric mounting threads)
5 837 370	(Same with UNC mounting threads)
3 837 390	Lightweight water cooling jacket with protection window
3 846 100	Mounting tube
3 846 120	Flange tube
3 837 540	Cooling plate for series 5 and 6, with air purge
3 846 620	Vacuum flange KF16 with protection window
3 846 650	Spare protection window, Ø 25 x 3 with Viton-O-ring

To ensure consistent document formatting, this page was intentionally left blank.

7 Troubleshooting

Before sending the pyrometer for repair, try to find the error and to solve the problem with the help of the following list.

Temperature indication too low

- Incorrect alignment of the pyrometer to the object.
⇒ New correct alignment to achieve the max. temperature signal (see **3.4**).
- Measuring object smaller than spot size.
⇒ Check measuring distance, smallest spot size is at nominal measuring distance (see **3.3**).
- Emissivity set too high.
⇒ Set lower correct emissivity slope corresponding to the material (see **4.3**).
- Lens contaminated
⇒ Clean lens carefully (see **6.2**)

Temperature indication too high

- Emissivity slope set too low.
⇒ Set lower correct emissivity slope corresponding to the material (see **4.3**).
- The measurement is influenced by reflections of hot machine parts.
⇒ Use mechanical construction to avoid the influence of the interfering radiation.

Measuring errors

- Indicated temperature is decreasing during the use of the pyrometer, contamination of the lens.
⇒ Clean lens. Recommendation: use of air purge (see **2.6, 6.2**).
- Indicated temperature is decreasing during the use of the pyrometer, although the air purge unit is used. Probably compressed air is not clean or air failed.
⇒ Clean the lens and use clean, dry and oil free compressed air.
- Air contamination in the sighting path between pyrometer and object
⇒ Change position of the pyrometer with a clean sighting path (if necessary use a ratio pyrometer).
- HF-interferences.
⇒ Correct the connection of the cable shield (see **3.1**).
- Instrument overheated
⇒ Use cooling jacket with air or water cooling (see **2.6**).
- Temperature Indication is fluctuating, probably caused by changing emissivity
⇒ Wrong pyrometer type, use of ratio pyrometer recommended

To ensure consistent document formatting, this page was intentionally left blank.

Index

A

Accessories 12
Appropriate use 9

C

Connection cable 9
Controls and Connections 13

D

Disposal 8

E

Electrical Installation 13
Emissivity 17

F

Factory settings 17

G

General 5

I

Installation, electrical 13

L

Legend 5
Liability 6

M

Maintenance 21

O

Optical head 14

P

Packaging 8
Parameter descriptions 17

R

Reference numbers 23
Repair 7
Response time / exposure time 19

S

Scope of delivery 9
Service Request 7
Settings 17
Storage 8
Support 7

T

Technical data 9
Transport, packaging, storage 8
Trouble shooting 25

U

Unpacking 6

W

Warranty 6